

Flygt 3069

3069.160/.190



Table of Contents

1 Introduction.....	2
1.1 Specially approved products.....	2
2 Product Description.....	3
2.1 The data plate.....	3
2.2 Approvals.....	4
2.3 Product denomination.....	5
3 Exploded View.....	7
3.1 Exploded view.....	7
3.2 N-pumps.....	8
4 List of Parts.....	9
4.1 3069.160/.190.....	9

1 Introduction

Purpose of this manual

The purpose of this manual is to provide necessary information on spare parts and accessories order.

Disclaimer

Always use genuine Flygt parts. The use of other spare parts or accessories can invalidate any claims for warranty or compensation. Xylem does not take any responsibility for damages that are caused by the use of non-original parts. For more information, contact your local sales and service representative.

Data for ordering spare parts

The following information is needed for spare part orders:

- Serial number of the product
- Part number
- Quantity of bulk material, see * in tables

1.1 Specially approved products

Qualification of personnel

Only Xylem or Xylem-authorized service personnel may undertake repair work on specially approved products.

Dimensional accuracy inspection

Spare parts marked with (Ex) after the part number are subject to dimensional accuracy inspection when used in specially approved products.

2 Product Description

Products included

Pump	D-hydraulic	F-hydraulic	M-hydraulic (Grinder)	N-hydraulic, cast iron	N-hydraulic, Hard-Iron™	N-hydraulic, stainless steel
3069.160				MT, SH		
3069.190 ¹				MT, SH		
¹ Explosion proof drive unit						

Pump-specific information

For the specific weight, current, voltage, power ratings, and speed of the pump, see the data plate of the pump.

2.1 The data plate

The data plate is a metal label that is located on the main body of the products. The data plate lists key product specifications. Specially approved products also have an approval plate.

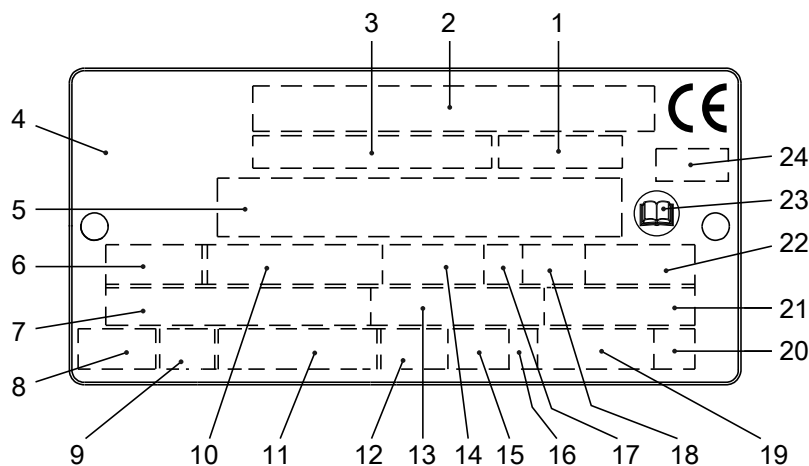

WS006257A

1. Curve code or Propeller code
2. Serial number
3. Product number
4. Country of origin
5. Additional information
6. Phase; type of current; frequency
7. Rated voltage
8. Thermal protection
9. Thermal class
10. Rated shaft power
11. International standard
12. Degree of protection
13. Rated current
14. Rated speed
15. Maximum submergence
16. Direction of rotation: L=left, R=right
17. Duty class
18. Duty factor
19. Product weight
20. Locked rotor code letter
21. Power factor
22. Maximum ambient temperature
23. Read installation manual
24. Notified body, only for EN-approved Ex products

Figure 1: The data plate

2.2 Approvals

Product approvals for hazardous locations

Pump	Approval
<ul style="list-style-type: none"> 3069.190 	European Norm (EN) <ul style="list-style-type: none"> ATEX Directive EN 60079-0:2012/A11:2013, EN 60079-1:2014, EN 13463-1:2009, EN 13463-5:2011 ⊕ II 2 G c Ex db IIB T3 Gb ⊕ II 2 G c Ex db IIB T4 Gb
	IEC <ul style="list-style-type: none"> IECEx scheme IEC 60079-0, IEC 60079-1 Ex d IIB T3 Gb Ex d IIB T4 Gb
	FM (FM Approvals) <ul style="list-style-type: none"> Explosion proof for use in Class I, Div. 1, Group C and D

EN approval plate

This illustration describes the EN approval plate and the information that is contained in its fields.

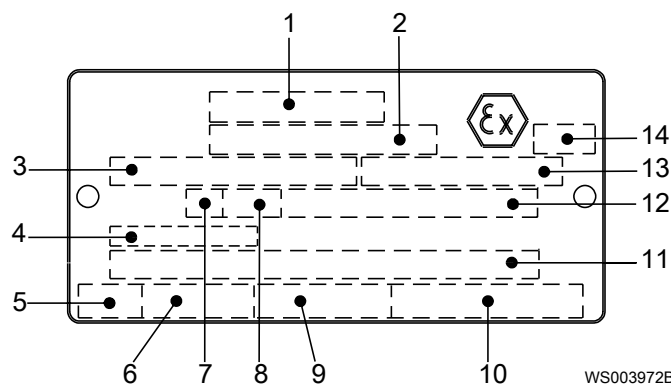

1. Approval
2. Approval authority and Approval number
3. Approved for drive unit
4. Cable entry temperature
5. Stall time
6. Starting current or Rated current
7. Duty class
8. Duty factor
9. Input power
10. Rated speed
11. Additional information
12. Maximum ambient temperature
13. Serial number
14. ATEX marking

IEC approval plate

This illustration describes the IEC approval plate and the information that is contained in its fields.

International Norm; not for EU member countries.

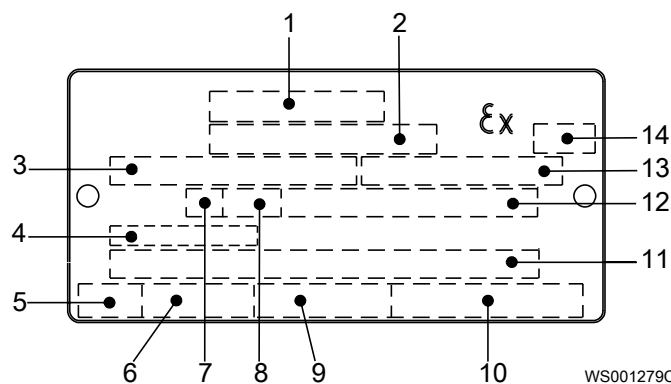

1. Approval
2. Approval authority and Approval number
3. Approved for drive unit
4. Cable entry temperature
5. Stall time
6. Starting current or Rated current
7. Duty class
8. Duty factor
9. Input power
10. Rated speed
11. Additional information
12. Maximum ambient temperature
13. Serial number
14. ATEX marking

FM approval plate

This illustration describes the FM approval plate and the information that is contained in its fields.

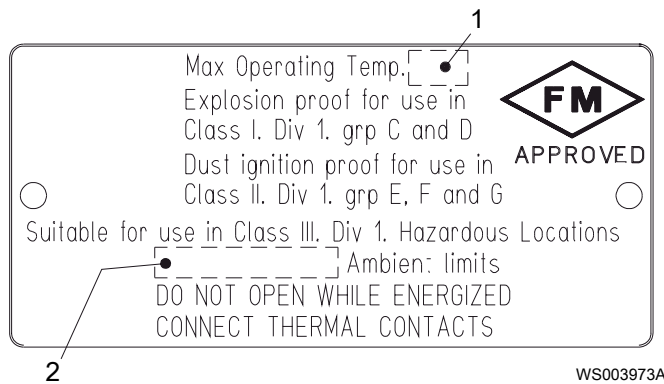

- 1. Temperature class
- 2. Maximum ambient temperature

CSA approval plate

This illustration describes the CSA approval plate and the information that is contained in its fields.

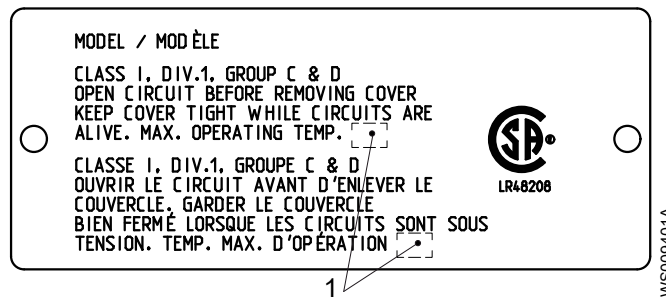

- 1. Temperature class

2.3 Product denomination

Reading instruction

In this section, code characters are illustrated accordingly:

X = letter

Y = digit

The different types of codes are marked up with a, b and c. Code parameters are marked up with numbers.

Codes and parameters

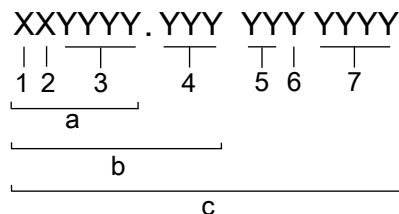

Type of Callout	Number	Indication
Type of code	a	Sales denomination
	b	Product code
	c	Serial number

Type of Callout	Number	Indication
Parameter	1	Hydraulic end
	2	Type of installation
	3	Sales code
	4	Version
	5	Production year
	6	Production cycle
	7	Running number

3 Exploded View

3.1 Exploded view

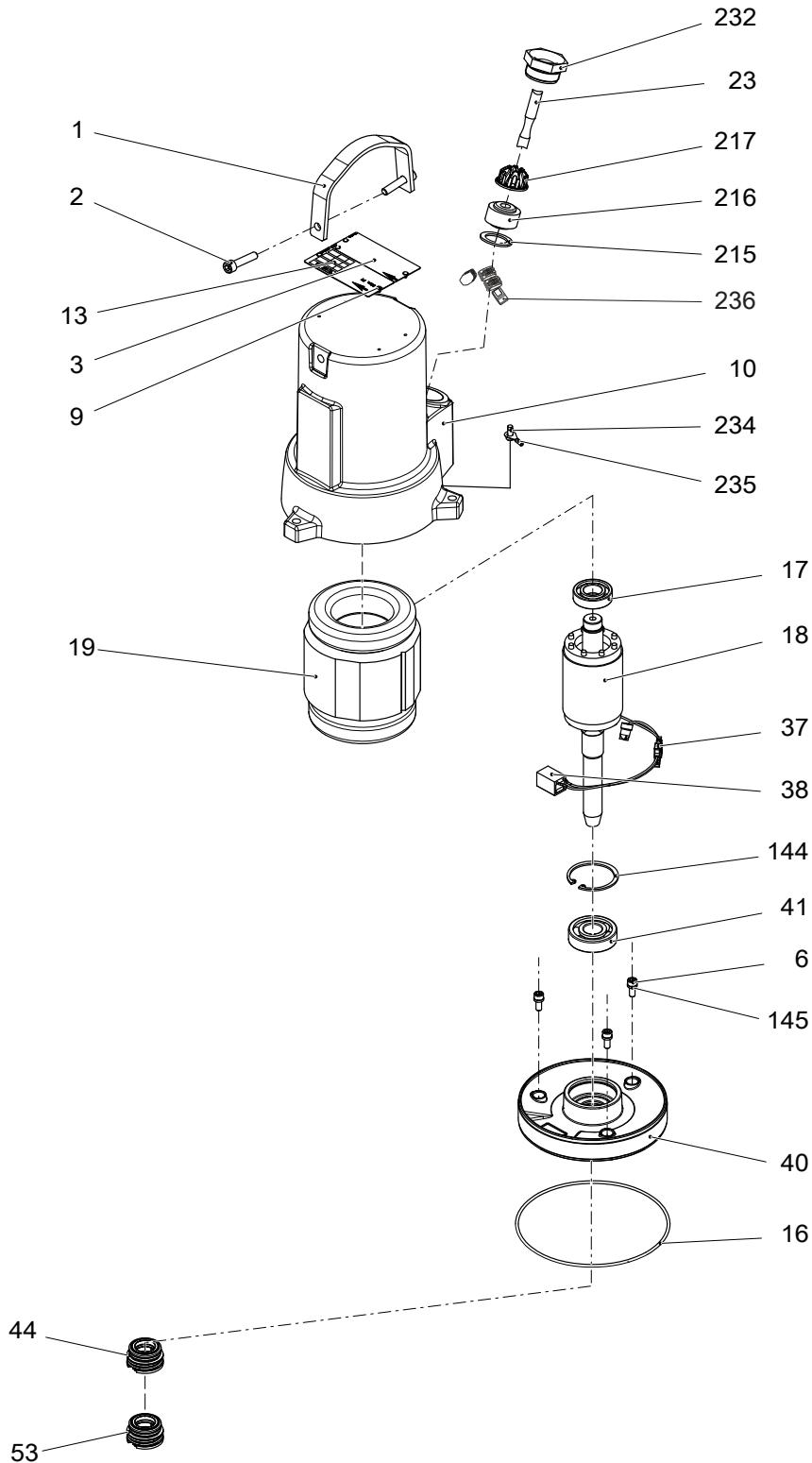

31588A

3.2 N-pumps

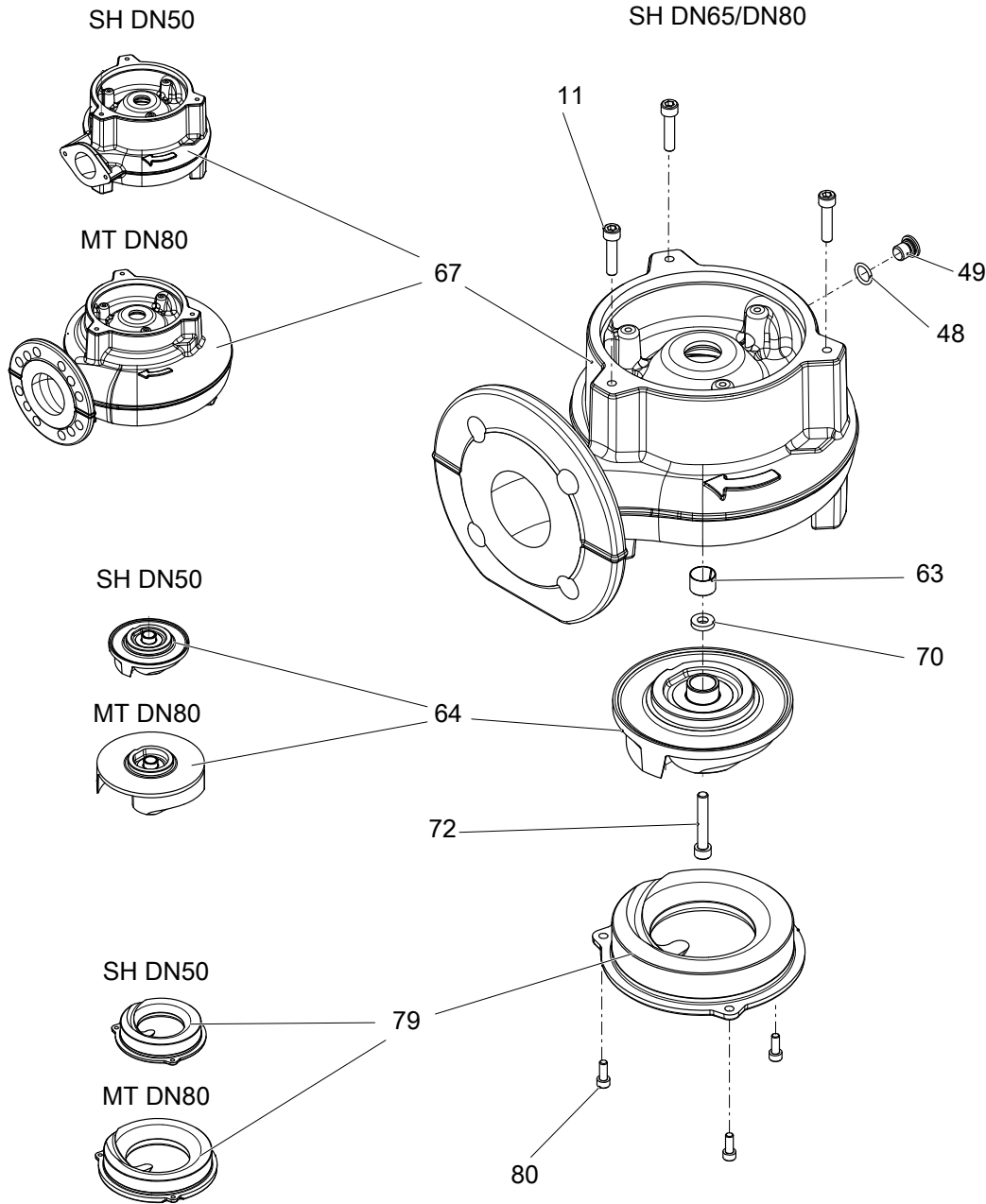

31592A

4 List of Parts

4.1 3069.160/.190

Pos. No	Part. No	Type	Denomination	Qty/Version	
				160	190
1	794 79 00		Lifting handle	1	1
2	85 00 37		Hex.socket hd screw ISO 4762 M 8 X35-A2-70	2	2
3	796 02 00	(Ex)	Data plate	2	2
6	82 00 13		Hex.socket hd screw M6X16-A2-70	3	3
9	82 20 88		Drive screw 4X5-A2/A4	4	4
9	82 20 88		Drive screw 4X5-A2/A4	2	2
10	794 21 00		Stator housing	1	
10	794 21 02		Stator housing Housing for CSA Canada	1	
10	794 21 01	(Ex)	Stator housing		1
11	83 04 45		Hex.socket hd screw M8X35-A4-80	3	3
13	796 06 00		Data plate	1	
16	82 78 26		O-ring 156X3 NBR	1	1
17	83 33 07		Ball bearing 6004-2Z	1	1
18	793 68 00		Shaft unit 13-08-2	1	1
18	793 68 02	(Ex)	Shaft unit 13-10-2	1	1
18	793 68 01	(Ex)	Shaft unit 13-10-2	1	1
18	793 71 00		Shaft unit 13-08-4	1	1
18	793 71 01	(Ex)	Shaft unit 13-10-4	1	1
19	638 93 01		Stator 13-08-2b 50 Hz 2-poles 220V-230V D 380V-400V Y P2=1,70kW 60 Hz 2-poles 440V-480V Y P2=2kW/2,70hp	1	1
19	638 93 03		Stator 13-08-2b 50 Hz 2-poles 415V-440V Y P2=1,70kW	1	1
19	638 93 04		Stator 13-08-2b 50 Hz 2-poles 500V-550V Y P2=1,70kW 60 Hz 2-poles 575V-600V Y P2=2kW/2,70hp 60 Hz 2-poles 575V-600V Y P2=1,50kW/2hp	1	1
19	638 93 05		Stator 13-08-2b 50 Hz 2-poles 400V D 690V Y P2=1,70kW	1	1
19	638 93 06		Stator 13-08-2b 60 Hz 2-poles 220V-230V Y// 440V-460V YSER P2=2kW/2,70hp	1	1
19	638 93 07		Stator 13-08-2b 50 Hz 2-poles 190V-200V Y P2=1,70kW 60 Hz 2-poles 200V-220V Y P2=2kW/2,70hp 60 Hz 2-poles 200V-220V Y P2=1,50kW/2hp	1	1
19	638 93 08		Stator 13-08-2b 60 Hz 2-poles 220V D 380V Y P2=2kW/2,70hp	1	1

Pos. No	Part. No	Type	Denomination	Qty/Version		
				160	190	
19	638 96 01	(Ex)	Stator 13-10-2b	1-phase 50 Hz 2-poles 220V-240V P2=1,50kW	1	1
19	638 96 03	(Ex)	Stator 13-10-2b	1-phase 60 Hz 2-poles 220V-240V P2=1,70kW/2,30hp	1	1
19	638 95 01		Stator 13-10-2b	50 Hz 2-poles 220V-230V D 380V-400V Y P2=2,40kW 60 Hz 2-poles 440V-480V Y Max P1=2,80KW 50 Hz 2-poles 220V-230V D 380V-400V Y Max P1=2,50KW 60 Hz 2-poles 440V-480V Y P2=2,80kW/3,80hp	1	1
19	638 95 03		Stator 13-10-2b	50 Hz 2-poles 415V-440V Y P2=2,40kW 50 Hz 2-poles 415V-440V Y Max P1=2,50KW	1	1
19	638 95 04		Stator 13-10-2b	50 Hz 2-poles 500V-550V Y P2=2,40kW 60 Hz 2-poles 575V-600V Y P1=2,70KW 50 Hz 2-poles 500V-550V Y Max P1=2,50KW 60 Hz 2-poles 575V-600V Y P2=2,80kW/3,80hp	1	1
19	638 95 05		Stator 13-10-2b	50 Hz 2-poles 400V D 690V Y P2=2,40kW 50 Hz 2-poles 400V D 690V Y P1=2,40KW	1	1
19	638 95 06		Stator 13-10-2b	60 Hz 2-poles 230V-240V Y// 460V-480V YSER P2=2,80kW/ 3,80hp	1	1
19	638 95 07		Stator 13-10-2b	50 Hz 2-poles 190V-200V Y P2=2,40kW 60 Hz 2-poles 200V-220V Y Max P1=2,90KW 50 Hz 2-poles 190V-200V Y Max P1=2,50KW 60 Hz 2-poles 200V-220V Y P2=2,80kW/3,80hp	1	1
19	638 95 08		Stator 13-10-2b	60 Hz 2-poles 220V-230V D 380V-400V Y Max P1=2,80KW 60 Hz 2-poles 220V-230V D 380V-400V Y P2=2,80kW/3,80hp	1	1
19	638 95 11		Stator 13-10-2b	60 Hz 2-poles 200V-208V Y Max P1=2,80KW 60 Hz 2-poles 200V-208V Y P2=2,80kW/3,80hp	1	1
19	657 86 01		Stator 13-08-4b	50 Hz 4-poles 230V D 400V-415V Y P2=1,50kW 60 Hz 4-poles 460V-480V Y P2=1,80kW/2,40hp	1	1
19	657 86 02		Stator 13-08-4b	50 Hz 4-poles 440V Y P2=1,50kW	1	1

Pos. No	Part. No	Type	Denomination	Qty/Version	
				160	190
19	657 86 03		Stator 13-08-4b 50 Hz 4-poles 500V Y P2=1,50kW 60 Hz 4-poles 575V-600V Y P2=1,80kW/2,40hp	1	1
19	657 86 04		Stator 13-08-4b 50 Hz 4-poles 400V D 660V-690V Y P2=1,50kW	1	1
19	657 86 05		Stator 13-08-4b 50 Hz 4-poles 200V Y P2=1,50kW	1	1
19	657 86 06		Stator 13-08-4b 60 Hz 4-poles 220V-230V D 380V Y P2=1,80kW/2,40hp	1	1
19	657 86 07		Stator 13-08-4b 60 Hz 4-poles 200V-208V Y P2=1,80kW/2,40hp	1	1
19	657 86 08		Stator 13-08-4b 60 Hz 4-poles 400V-415V Y P2=1,80kW/2,40hp	1	1
19	657 86 09		Stator 13-08-4b 50 Hz 4-poles 220V D 380V Y P2=1,50kW	1	1
19	657 86 10		Stator 13-08-4b 50 Hz 4-poles 550V Y P2=1,50kW	1	1
19	657 86 12		Stator 13-08-4b 60 Hz 4-poles 230V-240V Y// 460V YSER P2=1,80kW/2,40hp	1	1
19	656 12 01		Stator 13-10-4b 1phs 1-phase 50 Hz 4-poles 220V-240V P2=1,30kW	1	1
19	656 12 03		Stator 13-10-4b 1phs 1-phase 60 Hz 4-poles 230V-240V P2=0,97kW/1,30hp 1-phase 60 Hz 4-poles 230V-240V P2=1,50kW/2hp	1	1
19	656 13 01		Stator 13-10-4b 50 Hz 4-poles 400V-415V Y P2=2kW 60 Hz 4-poles 440V-480V Y P1=2,50KW 50 Hz 4-poles 400V-415V Y Max P1=2,30KW 60 Hz 4-poles 440V-480V Y P2=2,40kW/3,20hp	1	1
19	656 13 02		Stator 13-10-4b 50 Hz 4-poles 440V Y P2=2kW 50 Hz 4-poles 440V Y P1=2,20KW	1	1
19	656 13 03		Stator 13-10-4b 50 Hz 4-poles 500V Y P2=2kW 60 Hz 4-poles 575V-600V Y P1=2,50KW 50 Hz 4-poles 500V Y P1=2,20KW 60 Hz 4-poles 575V-600V Y P2=2,40kW/3,20hp	1	1
19	656 13 04		Stator 13-10-4b 50 Hz 4-poles 400V D 690V Y P2=2kW 50 Hz 4-poles 400V D 690V Y P1=2,20KW	1	1
19	656 13 05		Stator 13-10-4b 50 Hz 4-poles 200V Y P2=2kW 50 Hz 4-poles 200V Y P1=2,20KW	1	1
19	656 13 06		Stator 13-10-4b 60 Hz 4-poles 220V-230V D 380V Y Max P1=2,60KW 60 Hz 4-poles 220V-230V D 380V Y P2=2,40kW/3,20hp	1	1

Pos. No	Part. No	Type	Denomination	Qty/Version	
				160	190
19	656 13 07		Stator 13-10-4b 60 Hz 4-poles 200V-208V Y P1=2,50KW 60 Hz 4-poles 200V-208V Y P2=2,40kW/3,20hp	1	1
19	656 13 08		Stator 13-10-4b 60 Hz 4-poles 400V Y P1=2,50KW 60 Hz 4-poles 400V Y P2=2,40kW/ 3,20hp	1	1
19	656 13 09		Stator 13-10-4b 50 Hz 4-poles 220V D 380V Y P2=2kW 50 Hz 4-poles 220V D 380V Y P1=2,30KW	1	1
19	656 13 10		Stator 13-10-4b 50 Hz 4-poles 550V Y P2=2kW 50 Hz 4-poles 550V Y P1=2,20KW	1	1
19	656 13 13		Stator 13-10-4b 60 Hz 4-poles 230V-240V Y// 460V YSER P1=2,50KW 60 Hz 4-poles 230V-240V Y// 460V YSER P2=2,40kW/3,20hp	1	1
23	94 20 41		Motor cable subcab 4G1.5	*	*
23	94 20 42		Motor cable subcab 4G2.5	*	*
23	94 20 61		Motor cable subcab 4G1.5+2X1.5	*	*
23	94 20 59		Motor cable subcab 4G2.5+2X1.5	*	*
23	94 20 82		Motor cable subcab 7G2.5+2X1.5	*	*
23	94 19 89		Motor cable subcab S3X1.5+3X1.5/3+S(2X0.5)	*	*
23	94 19 90		Motor cable subcab S3X2.5+3X2.5/3+S(4X0.5)	*	*
37	504 78 07		Cable unit	1	1
38	518 89 02		Leakage sensor (FLS)	1	1
40	539 83 00		Bearing holder GD-AL	1	
40	516 79 01	(Ex)	Bearing holder		1
41	83 33 13		Ball bearing 20X52X15 MM	1	1
44	720 45 07		Mechanical seal AL2O3/CARBON FPM	1	1
44	720 45 00		Mechanical seal WCCR/WCCR FPM	1	1
48	85 02 73		Seal washer	1	1
49	85 02 64		Plug	1	1
53	720 45 01		Mechanical seal AL2O3/WCCR FPM	1	1
53	720 45 00		Mechanical seal WCCR/WCCR FPM	1	1
63	397 88 00		Sleeve	1	1
64	794 68 00		Impeller unit MT Curve code: 430	1	1
64	794 68 01		Impeller unit MT Curve code: 432	1	1
64	794 68 02		Impeller unit MT Curve code: 433	1	1
64	794 68 03		Impeller unit MT Curve code: 434	1	1
64	794 68 04		Impeller unit MT Curve code: 436	1	1
64	794 59 00		Impeller unit SH Curve code: 270	1	1
64	794 59 01		Impeller unit SH Curve code: 272	1	1
64	794 59 02		Impeller unit SH Curve code: 274	1	1

Pos. No	Part. No	Type	Denomination	Qty/Version		
				160	190	
64	794 59 05		Impeller unit	SH Curve code: 275	1	1
64	794 59 06		Impeller unit	SH Curve code: 276	1	1
67	794 47 00		Pump housing	MT N DN 80 Drilled acc. to: EN 1092-2 tab. 9 ANSI B16.1-89; tab.5 Installation: X Outlet diameter (mm): 80	1	
67	794 46 02		Pump housing	SH N DN 65 Installation: X Outlet diameter (mm): 65	1	
67	794 46 05		Pump housing	SH N DN 80 Installation: X Outlet diameter (mm): 65	1	
67	794 40 00		Pump housing	SH N DN 50 Installation: X Outlet diameter (mm): 50	1	
67	794 47 01	(Ex)	Pump housing	MT N DN 80 Drilled acc. to: EN 1092-2 tab. 9 ANSI B16.1-89; tab.5 Installation: X Outlet diameter (mm): 80		1
67	794 46 01	(Ex)	Pump housing	SH N DN 65 Installation: X Outlet diameter (mm): 65		1
67	794 46 04	(Ex)	Pump housing	SH N DN 80 Installation: X Outlet diameter (mm): 65		1
67	794 40 01	(Ex)	Pump housing	SH N DN 50 Installation: X Outlet diameter (mm): 50		1
70	652 53 00		Supporting washer		1	1
72	82 00 39		Hex.socket hd screw M8X50-A2-70		1	1
79	794 53 00		Suction cover	MT	1	1
79	783 07 01		Insert ring	SH	1	1
80	82 00 13		Hex.socket hd screw M6X16-A2-70		3	3
144	82 62 07		Retaining ring SGH 52		1	1
145	82 50 60		Sealing washer DUBO NR 301		3	3
215	82 40 61		Plain washer 24.5X35X2-A2-70		1	1
216	84 37 95		Seal sleeve (10)-12 MM NBR		1	1
216	84 37 96		Seal sleeve (12)-14 MM NBR		1	1
216	84 37 97		Seal sleeve (14)-16 MM NBR		1	1
216	84 37 98		Seal sleeve (16)-18 MM NBR		1	1
216	84 38 00		Seal sleeve (20)-22 MM NBR		1	1
216	84 37 99		Seal sleeve (18)-20 MM NBR		1	1
217	678 58 12	(Ex)	Cable clip 10-(12) MM		1	1
217	678 58 14	(Ex)	Cable clip 12-(14) MM		1	1
217	678 58 16	(Ex)	Cable clip 14-(16) MM		1	1
217	678 58 18	(Ex)	Cable clip 16-(18) MM		1	1
217	678 58 22	(Ex)	Cable clip 20-(22) MM		1	1
217	678 58 20	(Ex)	Cable clip 18-(20) MM		1	1
232	397 81 00	(Ex)	Gland screw Pr 37		1	1
234	82 17 61		Cutting screw TAPTITE-M6X12		1	1
235	83 43 58		Cable lug UL/CSA 1.04-2.62 MM2 M6		1	1
235	83 43 62		Cable lug UL/CSA 0.50-1.65 MM2 M6		1	1

Pos. No	Part. No	Type	Denomination	Qty/Version		
				160	190	
236	83 42 65		Terminal block 600V/20A UL	5	5	
236	83 42 67		Terminal block 600V/20A UL	1	1	
236	83 44 23		Closed-end splice 4.0-9.0 (AWG 8)	2	2	
236	83 44 24		Closed-end splice 3-6 (AWG 12-10)	5	5	
236	83 42 65		Terminal block 600V/20A UL	4	4	
236	83 42 67		Terminal block 600V/20A UL	4	4	
236	83 42 67		Terminal block 600V/20A UL	6	6	
800	85 00 51		O-ring kit	1	1	
900	801 01 00		Basic repair kit	AL203/WCCR AL203/C	1	1
900	801 01 01		Basic repair kit	WCCR/WCCR AL203/C	1	1
900	801 01 02		Basic repair kit	WCCR/WCCR WCCR/WCCR	1	1
901	90 17 52		Oil ISO VG 32	*	*	