



Flygt 2700 series

CORROSION RESISTANT DEWATERING PUMPS

50 Hz

FLYGT
POMP  IRECT

Extreme conditions call for extraordinary performance



Mines and quarries

Open pit and underground dewatering with low pH value liquids, face and stage dewatering, leachate and solvent extractions, ore pile runoff removal.



Industrial

Fly ash removal, chemical transfer and basin drainage, pH neutralization pumping



Chemical industry

Drainage of sumps with chemical effluents and low pH value liquids, transfer of chemical, corrosive and abrasive liquids.



Public utility

Utility drainage on land-fill sites, drainage of acid sumps at wastewater treatment plants, removal of acidic or corrosive liquids at contaminated sites.

Salt water, sludge and slurry, corrosive and abrasive liquids, and effluent with unpredictably high or low pH values. These are tough water transport challenges that require tough pumps. The Flygt 2700 series from Xylem are rugged stainless steel submersible dewatering pumps that handle tough drainage jobs and sludge removal with ease.

Withstands corrosive environments

Where other pumps demonstrate inferior corrosion-resistance, Flygt 2700 series pumps have proven successful in transporting corrosive and abrasive fluids as well as chemically contaminated liquids and suspensions. These cast stainless steel workhorses withstand the test of time in applications that would otherwise destroy aluminum or cast iron pumps in a few days or weeks.

Unmatched versatility

Acidity, alkalinity and abrasiveness. Flygt 2700 pumps can handle it all. These all-stainless pumps are excellent choices for tough environments with liquids that have pH values anywhere between 2 and 10. This versatility drastically reduces unplanned operational shutdowns due to pump failure.

More uptime with less maintenance

Because the Flygt 2700 series are made of top-grade stainless steel, the pumps are durable beyond belief. That greatly reduces the need for repairs and the associated costs.

Gets tough unwanted water going

Flygt 2700 submersible drainage and sludge pumps move unwanted water with ease. All told, that spells reduced maintenance and more uptime.

Stainless steel when nothing else helps

Corrosive environments call for something tougher, easier and more cost-effective to maintain than aluminium, cast iron or corrosion-protective coatings. That's why the Flygt 2700 series for dewatering applications in environments with extreme pH levels is part of Xylem's broad range of pumps for a wide variety of needs and applications.

Handles the very acidic to the very alkaline

Stainless steel enables our 2700 pumps to handle advanced drainage jobs in environments where the pH values are difficult to predict and can vary from between 2 and 10. This gives you optimal protection against all types of corrosion, even in exposed areas such as connections, as well as between the different components of the pump.

Slimline simplicity

Slimline Flygt 2700 pumps fit easily into confined spaces and can easily be moved whenever necessary. A convenient ring-shaped handle supports good manoeuvrability during installation, and serves as a sturdy stand when you turn the pump upside down for service.

Reliable, trouble-free operation

For the ultimate uptime, count on the Flygt 2700 series for continuity. Well-engineered and easy to use, these pumps offer simplicity in stainless steel. Few streamlined components contribute to unmatched robustness, handling ease and cost-effective spare parts handling.



Flygt 2700 pumps can handle pH values from 2 to 10.

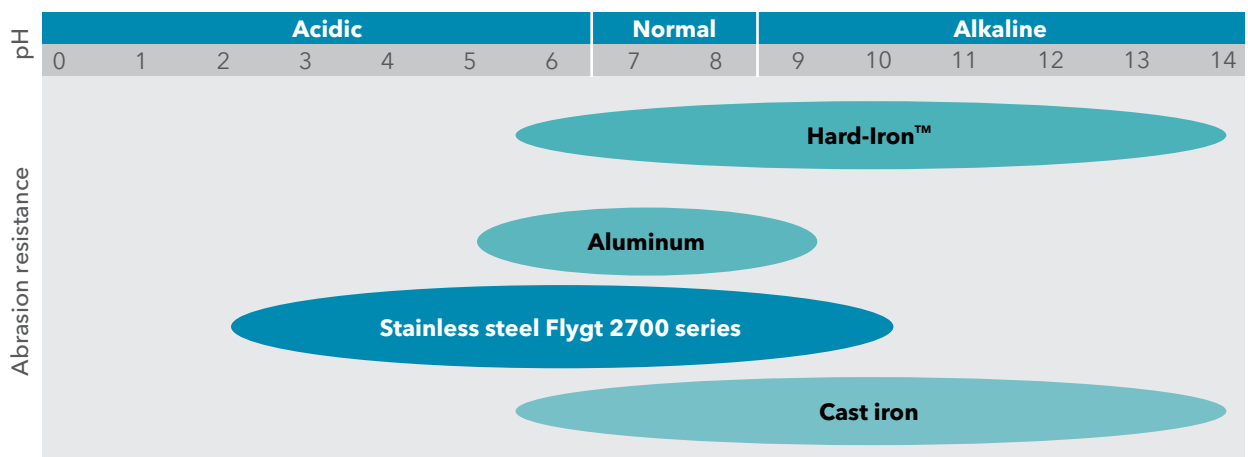

Highest quality throughout

Ring-shaped handle
Designed for good manoeuvrability. Also works as a sturdy stand during maintenance.

Turnable outlet
Vertical or horizontal outlet connection.

Motor
Short-circuited, high-performance motor in insulation class F (+155°C) for submersible operation that allows 15 starts per hour. The stainless steel stator housing has three integrated thermo-sensors.

Stainless steel impeller
Tailored to work efficiently and for a long time in extreme environments.

Removable junction box cover
Makes it easier to access the pump's electrical components.

Corrosion - and impact-resistant outer casing
Stainless steel throughout, for better durability in tough environments.

Double mechanical shaft seals
Work independently of each other. The same seal fits all Flygt 2700 series pumps.

Adjustable diffusers
For optimized performance.



Solids handling version

External oil and inspection plugs
Smart location and easy to access. Simplifies service and maintenance.

Recessed vortex impeller
Reduces wear on the wheel. Greater throughflow enables the pump to handle larger particles.

Freely adjustable turnable outlet
Provides added flexibility at the outlet connections.

Robust stand in stainless steel
Adds steadiness and stability. Creates free passage for larger particles.

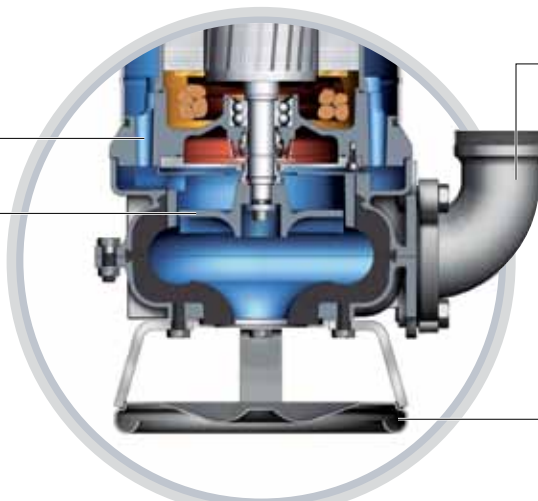

Find the right model for your needs

Drainage pumps for corrosive applications

The Flygt BS 2720.390, 2740.390 and 2750.390 pumps handle water that contains abrasive particles and particles in suspensions up to 25×7 mm in size. Available in both high head and high flow versions.

Sludge pumps for corrosive applications

The Flygt DS 2720.280, 2730.280 and 2740.280 pumps handle light slurry, different types of mud and sludge, and heavily contaminated water that contains abrasive particles, particles in suspensions up to 80 mm in size.



BS 2720

BS 2740 MT/HT

BS 2750 MT/HT



DS 2720

DS 2730 MT

DS 2740 HT

Performance curves

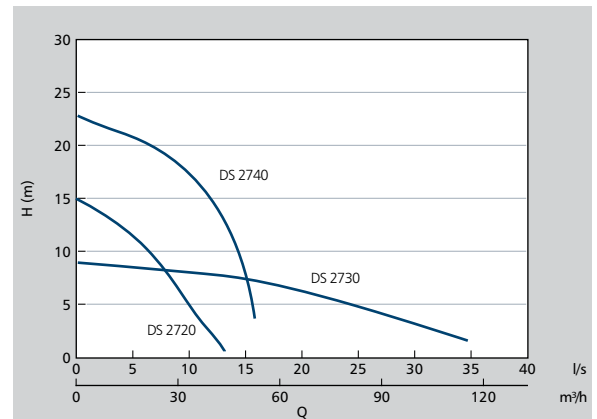
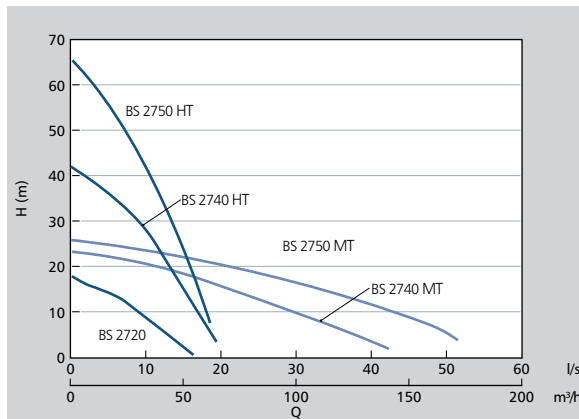

Dimensions and capacities

	BS 2720	BS 2740	BS 2750
Rating, [kW]	2.0	6.3	8.0
Height, [mm]	600	730	785
Width, [mm]	235	280	280
Strainer hole, [mm]	25×7	25×7	25×7

	DS 2720	DS 2730	DS 2740
Rating, [kW]	2.0	4.1	5.6
Height, [mm]	715	755	755
Width, [mm]	420	480	480
Throughlet, [mm]	50	75/80	46

Boost versatility and performance

Raise the performance of Flygt 2700 pumps by selecting options and accessories specially designed to simplify pump installation and operation.

Options

Starters (Manual and automatic)

Provide thermal/magnetic overload protection, thermal contact supervision and phase sequence indication.

Outlets

Enable convenient attachment of a hose or threaded connections for side discharge. Available as 3" and 4" outlets, with or without threaded connections, and adjustable to vertical or horizontal position.

Discharge connections

Enables fast connection and removal through quick-couplings in cast iron. Available for high-wear applications.

SUBCAB® cable

Submersible cable.

Special cables*

For power supply that withstands high temperatures, high voltage and chemical agitation.

Accessories

Check valve

Prevents backflow.

Level regulators

Controls operation by starting or stopping the pump or actuating an alarm.

Flygt pump raft

Keeps the pump afloat using lightweight glass-fiber reinforced polymer.

Water suction and discharge hose

Handles corrosive and abrasive liquids with wide variances in pH levels.

Cable protection hose

Provides physical protection for electric cables in applications involving water and/or oil.



Adjustable outlet. Enables vertical and horizontal pumping.



Flygt SUBCAB® cable. Provides high-quality protection of cable when submersed in liquid.



Flygt pump raft*. Enables the pump to adjust to changing water levels.

* Available only for drainage versions.