



Hidrostat

The appropriate **HIDROSTAL bearing frame** is the optimal and most economic solution for every pump configuration

- *Rigid construction for stable power transfer*
- *Centred configuration for flexible couplings*
- *Service-friendly construction with long-life seals*
- *Developed for a service life of $\geq 50,000$ working hours*



HIDROSTAL – Pioneers in Pump Technology

For Heavy-Duty Operation and Long Service Life

Bearing frames with HIDROSTAL precision protect the drive motor and the pump against early wear.

HIDROSTAL standard tandem seal construction with oil chamber.

A minimum axial play D_A means reliability and a long service life for the mechanical seal.

The wearing parts of the coupling are designed to last for the complete service life of the pump.

The standard motor is centred to the bearing frame via a seat. The shaft is therefore perfectly aligned, and requires no subsequent adjustment.

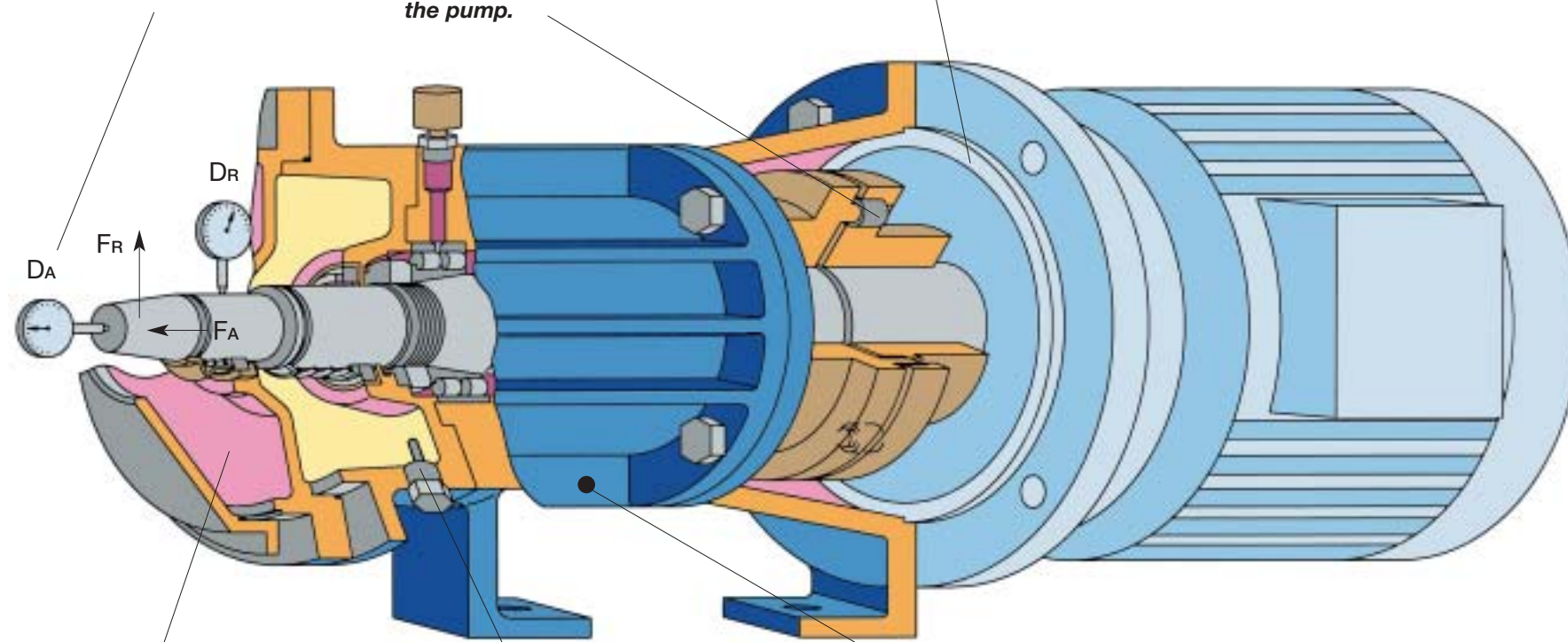

Large-area seal cavity

Seal leakage monitoring elements

Oscillation monitoring elements

The overall cost – related to service life – is an important factor in the detail layout of the optimal pump. The HIDROSTAL bearing frame, whose construction is designed for the heaviest loading, and thereby the minimum shaft deflection, decisively extends the service life of the pump.

Monitoring elements for seal leakage, bearing temperature and any oscillation that may take place can be built in as options.

Installation of cartridge seals or other seal types on request. With solids, HIDROSTAL recommends the standard tandem seal arrangement.

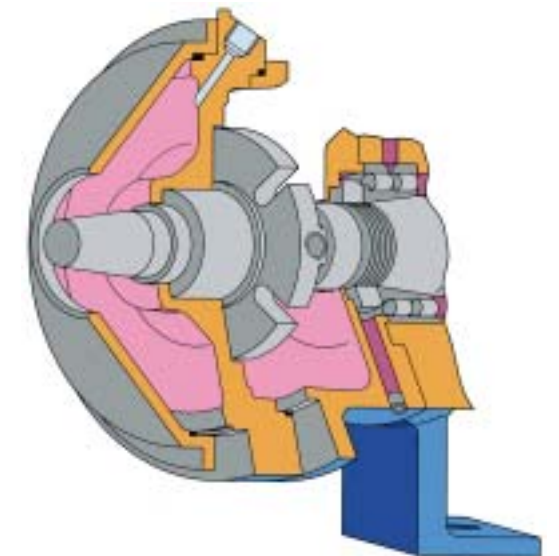

The split glands ensure simple replacement of the gaskets.

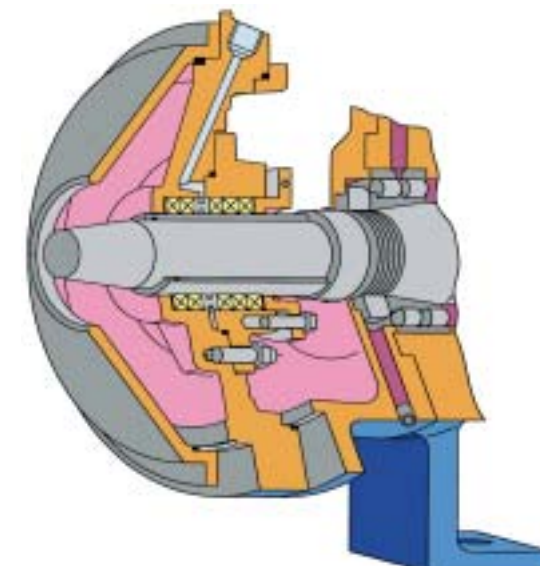

The practically clearance-free precision bearing frame has minimum shaft deflection and large-area seal surroundings. These are optimal conditions for the shaft seals.

The diagram shows values of the shaft deflection D_R as a function of the radial hydraulic force F_R of a conventional bearing frame compared with a HIDROSTAL precision bearing frame, in which the bearing play and the other equipment parts are compensated.

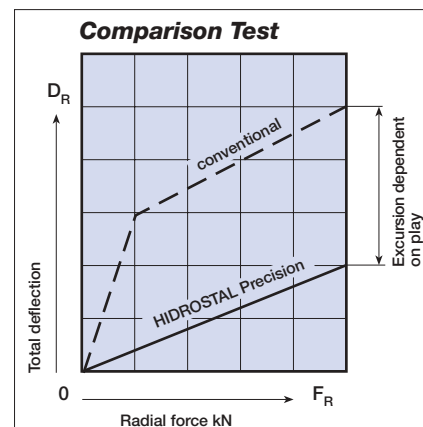

Minimum maintenance of the packing glands thanks to the precision bearings.

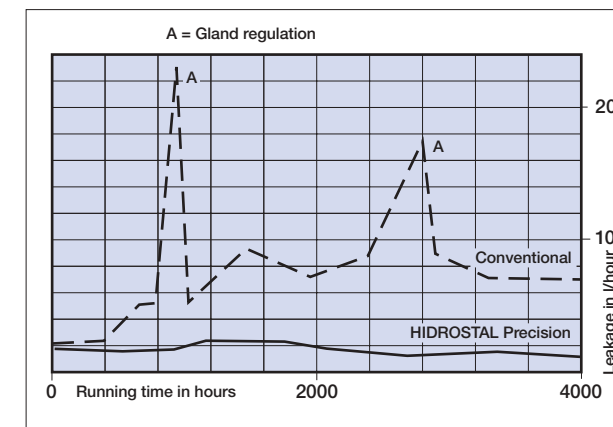

Rigid Power Transfer and Service-friendly Construction

HIDROSTAL Bearing Frame Pumps

are bearing and shaft-seal groups which, together with the hydraulics, form the pump unit. Bearing frame pumps are mostly installed in dry areas, e.g., together with other process machinery. This type of pump is also used for larger power levels (> 30 kW).

Advantages:

- Direct access to the pump and to the monitoring devices
- Maintenance in a clean environment
- Commercially-available drive elements can be used
- Wet installation with a hydraulic or compressed air motor, or installation as a vertical wet pump with a standard electrical motor in levels subject to flooding is possible
- Robust construction for smooth operation
- Service life of 50,000 operational hours, with appropriately-designed bearings. On customer request, the service life can be significantly increased by a small correction of the speed limits.

This construction, with a baseplate for rapid dismantling, enables simple checking in cases of over-large solids, difficult-to-handle media behaviour or where excessive abrasion or corrosion can be expected.

Pump with swivelled drive unit.

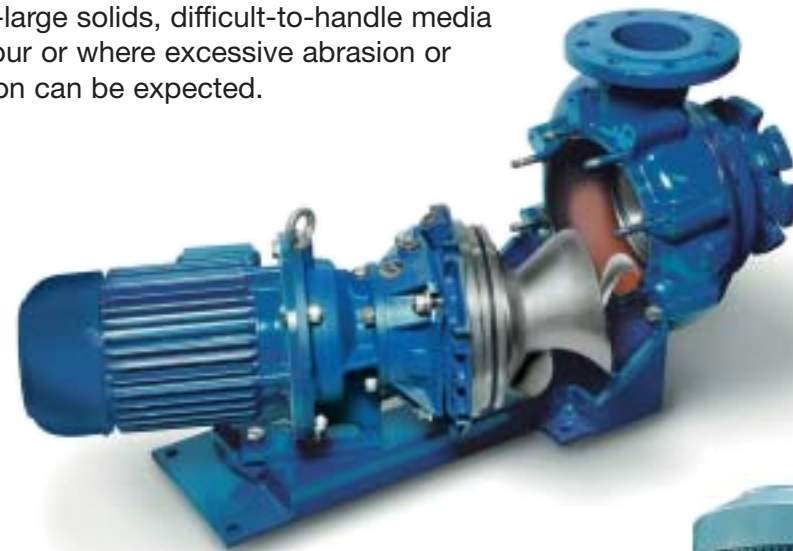

Vertically-arranged pumps with special, place-saving suction stand.



Heavy-duty process pump for horizontal or vertical installation in unscreened sewage lift stations, in sewage treatment plants and commercial and industrial pumping stations.



Process pumps with free shaft-ends are possible in many types of layout and drive types. Further couplings can be made at the free shaft-end.

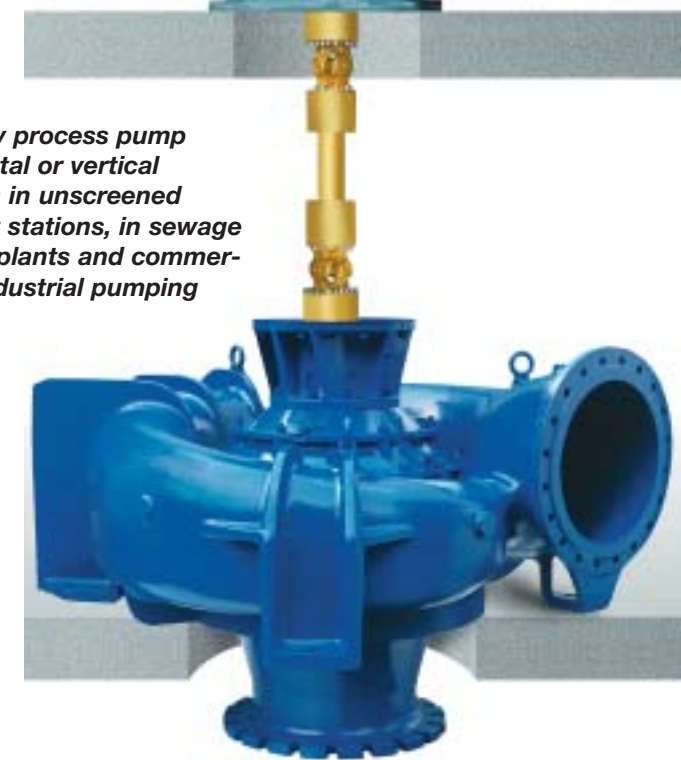

HIDROSTAL precision bearing frame pumps are characterised by an optimal price-performance ratio



Process pumps installed horizontally on a base-plate for fast service.



Returned sludge pump installed on a rotating scraper bridge.



Process pump installation with belt drive for viscous media such as oils, paints and adhesives.



Two-stage transportation system with space-saving suction stand and transition diffuser.

POMP DIRECT

Tel. 0294-457712 Fax 0294-457713

Hidrostal

HIDROSTAL AG
CH-8213 Neunkirch Schweiz/Switzerland
Phone ..41/52/687 06 87 Fax ..41/52/681 20 84