

Pump type: Submersible vortex pump
 Application: Waste water, sewage

Pump data

Solids passage 65 mm
 Discharge/ Suction diameter 65 mm/ 65 mm
 Impeller type: Vortex
 Impeller diameter 125 - 95 mm
 Recommended min. flow 2 l/sec (8 m3/h)
 Weight 45 kg

Motor

Mains: 50 c/s – 3 phase
 Rated shaft power 2.2 kW
 Rated electrical power 2.8 kW
 Nominal speed 2830 rpm
 Motor efficiency 79 %
 Power factor (cos phi) 0.89
 Degree of protection IP 68
 Isolation class F (155°C)
 Max. water temperature 40°C
 Standard cable length 10 m

Materials

Pump casing Cast iron GG 25 (EN-GJL-250)
 Impeller Cast iron GG 25 (EN-GJL-250)
 Motor unit Cast iron GG 25 (EN-GJL-250)
 Shaft AISI 431
 Alt: AISI 316
 Bolts AISI 316
 Elastomers Nitrile (NBR) or neoprene (CR)
 Alt: viton (FPM)
 Neoprene (CR)
 Electrical cable Neoprene (CR)
 Seal lubrication Oil
 Seal pump side Silicon carbide – silicon carbide
 Seal motor side Carbon - Ceramic
 Coating Two components polyurethane

Installation options

Header coupling BWK 065 or 080



Guide bar coupling OWK 065 or 080



Freestanding Including support (VRS) 75 mm hose connection or G 3" threaded connection



Optional

- Flameproof version, to class: II 2 G Ex d IIB c T4
 Standard: II 2 G Ex b c d IIB T4 Gb
 With Frequency control: II 2 G Ex b c d IIB T3 Gb
- Thermo switches in stator windings (standard for flame proof version)
- Cable protective sheathing (AISI 316)
- Water detector in motor and oil chamber
 Flameproof version with external cable

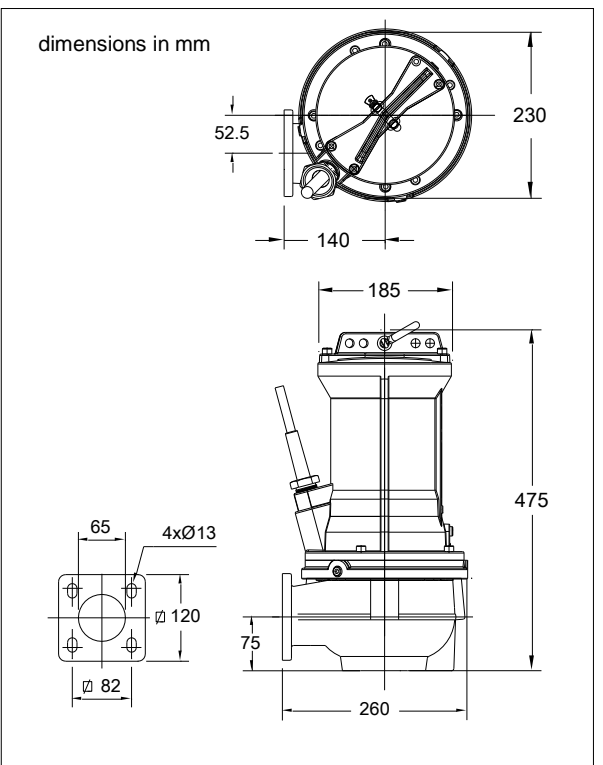
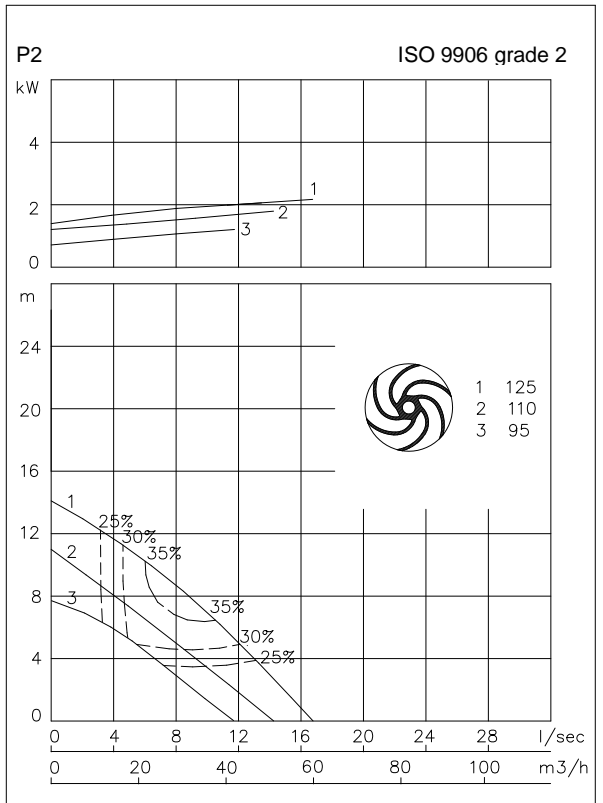

Connections

voltage [V]*	current [A]	Electrical cable size [mm ²]		motor protection and/or water detector		flameproof version	
		direct start		direct start		direct start	
230	7.9	4G1.5		7G1.5		7G1.5	
400	4.5	4G1.5		7G1.5		7G1.5	
500	3.6	4G1.5		7G1.5		7G1.5	
starting current DOL start : 5.3 x rated current							
* other voltages on request							